

\* TOEPC7106171DB

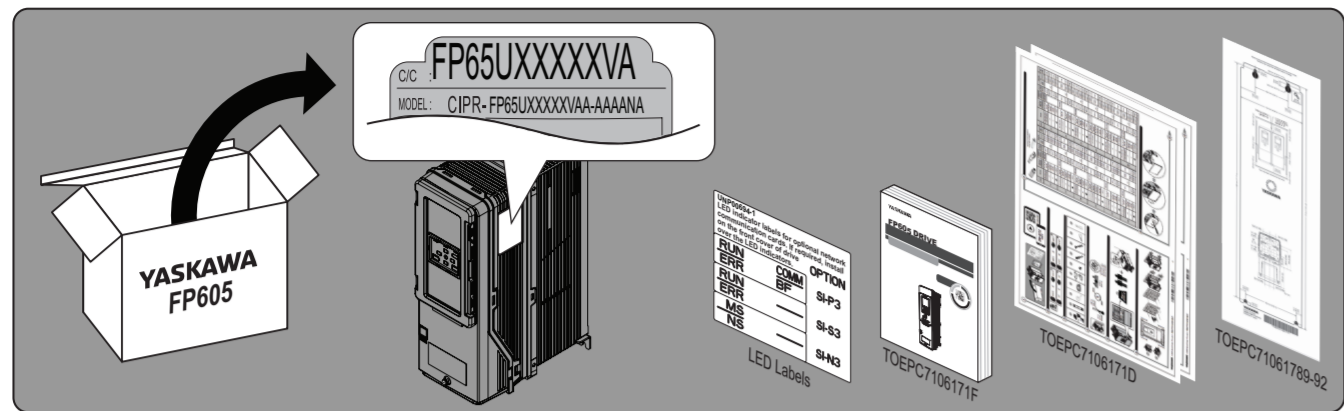

- Read and follow the safety and installation procedures in the Installation & Primary Operation (TOEPC7106171F) manual packaged with the drive.
- When you install an SI-P3, SI-S3, or SI-N3 communication option, you must also use the applicable LED label for your option. LED labels are included with the Installation & Primary Operation (TOEPC7106171F) manual.

**1 Confirm the Drive and Motor Specifications**

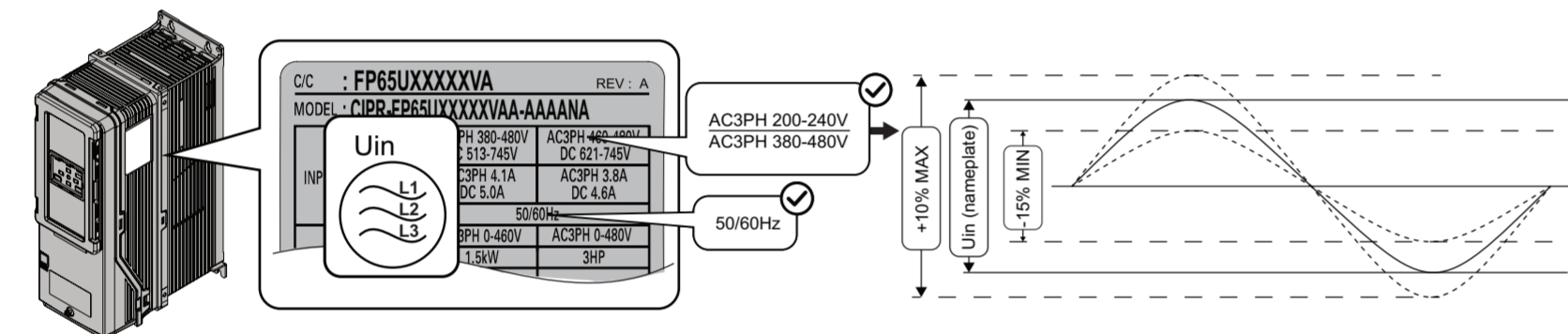
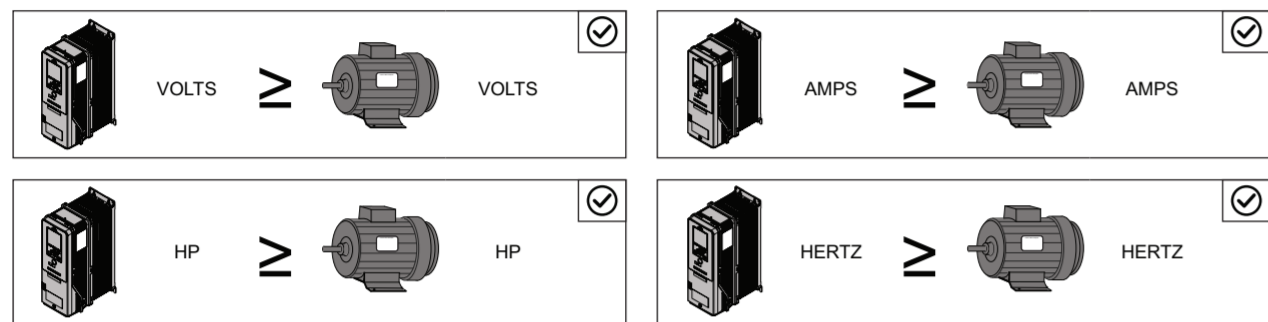

**2 Confirm the Correct Drive Installation Environment**

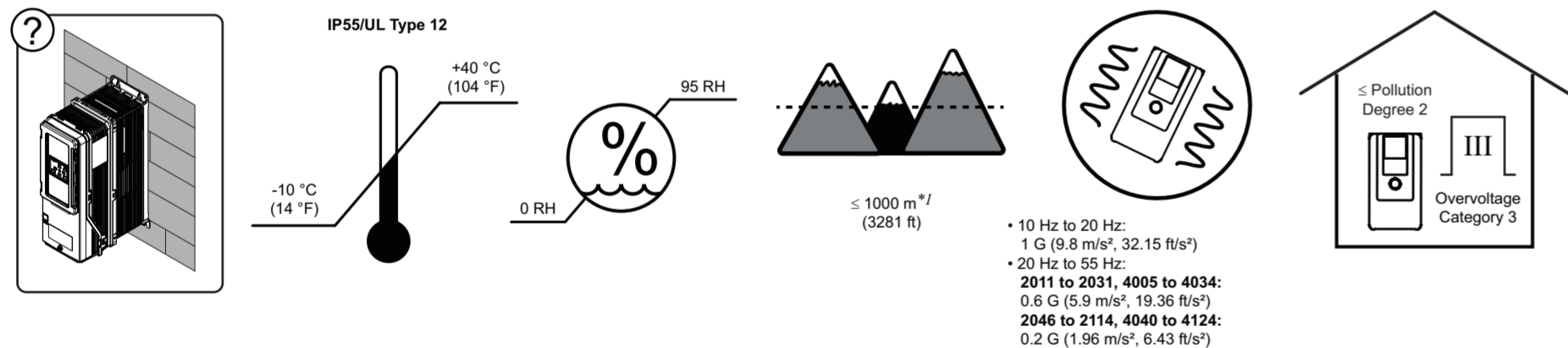

\*1 Derate the output current by 1% for each 100 m (328 ft) to install the drive in altitudes between 1000 m to 4000 m (3281 ft to 13123 ft). Refer to the Technical Reference (SIEPC7106171F) for derating information.

**3 Use the Enclosed Drilling Template to Mount the Drive Vertically**

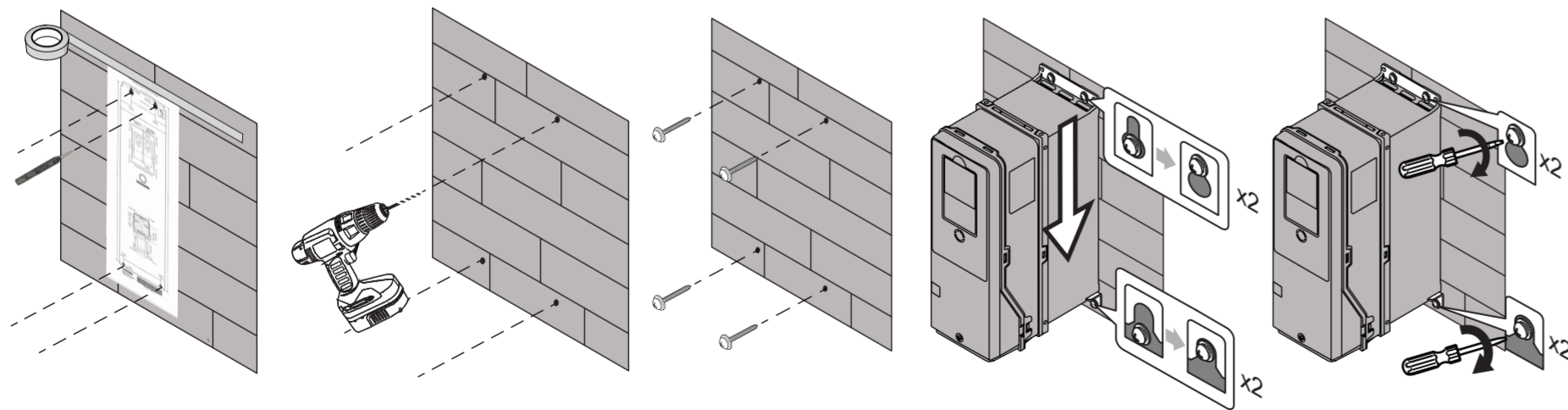

When you use non-metric hardware to install the drive, use Type B narrow washers or equivalent and make sure that the size of the screw head and washer are applicable for your drive before installation.

**4 Select the Motor and Power Wires, Wire Strip Length, Crimp Terminals, and Branch Circuit Protection**

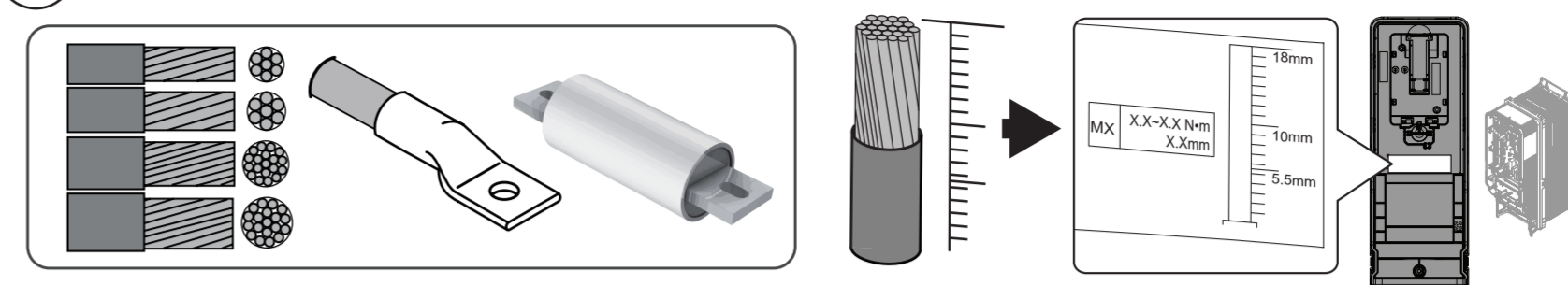

**240 V Wires and Crimp Terminals**

Drive Model [FP65UXXXX]	Terminal	Wire Range AWG/kcmil (mm²) <sup>†</sup>	Recommended Wire Gauge AWG/kcmil	Panduit Crimp Terminal Part Number <sup>*2,*3</sup>	Drive Model [FP65UXXXX]	Terminal	Wire Range AWG/kcmil (mm²) <sup>†</sup>	Recommended Wire Gauge AWG/kcmil	Panduit Crimp Terminal Part Number <sup>*2,*3</sup>	Drive Model [FP65UXXXX]	Terminal	Wire Range AWG/kcmil (mm²) <sup>†</sup>	Recommended Wire Gauge AWG/kcmil	Panduit Crimp Terminal Part Number <sup>*2,*3</sup>
2011	RL1, SL2, TL3 UT1, VT2, WT3	14 - 8 (2.5 - 10)	14	N/A	2031	RL1, SL2, TL3 UT1, VT2, WT3	14 - 8 (2.5 - 10)	8	N/A	2075	RL1, SL2, TL3	8 - 2/0 (10 - 70)	4	LCA4-56-L
	-, +1	14 - 8 (2.5 - 10)	14	N/A		-, +1	14 - 8 (2.5 - 10)	8	N/A		UT1, VT2, WT3	8 - 2/0 (10 - 70)	3 or 2	LCA4-56-LCA2-56-Q
	⊕	14 - 8 (2.5 - 10)	12	LCA10-14-L		⊕	14 - 8 (2.5 - 10)	10	LCA10-14-L		⊕	8 - 2/0 (10 - 70)	2	LCA2-56-Q
2017	RL1, SL2, TL3 UT1, VT2, WT3	14 - 8 (2.5 - 10)	12	N/A	2046	RL1, SL2, TL3 UT1, VT2, WT3	14 - 4 (2.5 - 25)	8	N/A	2088	RL1, SL2, TL3	8 - 2/0 (10 - 70)	3 or 2	LCA4-56-LCA2-56-Q
	-, +1	14 - 8 (2.5 - 10)	10	N/A		-, +1	14 - 4 (2.5 - 25)	6	N/A		UT1, VT2, WT3	8 - 2/0 (10 - 70)	2	LCA2-56-Q
	⊕	14 - 8 (2.5 - 10)	10	LCA10-14-L		⊕	14 - 4 (2.5 - 25)	8	LCA8-14-L		⊕	8 - 2/0 (10 - 70)	1	LCA1-56-E
2024	RL1, SL2, TL3 UT1, VT2, WT3	14 - 8 (2.5 - 10)	10	N/A	2059	RL1, SL2, TL3 UT1, VT2, WT3	14 - 4 (2.5 - 25)	4	N/A	2114	RL1, SL2, TL3	8 - 2/0 (10 - 70)	1/0	LCA1/0-56-X
	-, +1	14 - 8 (2.5 - 10)	8	N/A		-, +1	14 - 4 (2.5 - 25)	4	N/A		UT1, VT2, WT3	8 - 2/0 (10 - 70)	2/0	LCA2/0-56-X
	⊕	14 - 8 (2.5 - 10)	10	LCA10-14-L		⊕	14 - 4 (2.5 - 25)	6	LCA6-14-L		⊕	8 - 2/0 (10 - 70)	6	LCA6-56-L

**480 V Wires and Crimp Terminals**

Drive Model [FP65UXXXX]	Terminal	Wire Range AWG/kcmil (mm²) <sup>†</sup>	Recommended Wire Gauge AWG/kcmil	Panduit Crimp Terminal Part Number <sup>*2,*3</sup>	Drive Model [FP65UXXXX]	Terminal	Wire Range AWG/kcmil (mm²) <sup>†</sup>	Recommended Wire Gauge AWG/kcmil	Panduit Crimp Terminal Part Number <sup>*2,*3</sup>	Drive Model [FP65UXXXX]	Terminal	Wire Range AWG/kcmil (mm²) <sup>†</sup>	Recommended Wire Gauge AWG/kcmil	Panduit Crimp Terminal Part Number <sup>*2,*3</sup>
4005 4008	RL1, SL2, TL3 UT1, VT2, WT3	14 - 8 (2.5 - 10)	14	N/A	4027	RL1, SL2, TL3 UT1, VT2, WT3	14 - 8 (2.5 - 10)	10	N/A	4065	RL1, SL2, TL3	14 - 4 (2.5 - 25)	4	N/A
	-, +1	14 - 8 (2.5 - 10)	14	N/A		-, +1	14 - 8 (2.5 - 10)	8	N/A		-, +1	14 - 4 (2.5 - 25)	4	N/A
	⊕	14 - 8 (2.5 - 10)	14	LCA10-14-L		⊕	14 - 8 (2.5 - 10)	8	N/A		⊕	14 - 4 (2.5 - 25)	6	LCA6-14-L
4011	RL1, SL2, TL3 UT1, VT2, WT3	14 - 8 (2.5 - 10)	14	N/A	4034	RL1, SL2, TL3 UT1, VT2, WT3	14 - 8 (2.5 - 10)	8	N/A	4077	RL1, SL2, TL3	8 - 2/0 (10 - 70)	4	LCA4-56-L
	-, +1	14 - 8 (2.5 - 10)	14	N/A		-, +1	14 - 8 (2.5 - 10)	8	N/A		UT1, VT2, WT3	8 - 2/0 (10 - 70)	3 or 2	LCA4-56-LCA2-56-Q
	⊕	14 - 8 (2.5 - 10)	12	LCA10-14-L		⊕	14 - 8 (2.5 - 10)	8	N/A		⊕	8 - 2/0 (10 - 70)	2	LCA2-56-Q
4014	RL1, SL2, TL3 UT1, VT2, WT3	14 - 8 (2.5 - 10)	14	N/A	4040	RL1, SL2, TL3 UT1, VT2, WT3	14 - 4 (2.5 - 25)	8	N/A	4096	RL1, SL2, TL3	8 - 2/0 (10 - 70)	2	LCA2-56-Q
	-, +1	14 - 8 (2.5 - 10)	12	N/A		-, +1	14 - 4 (2.5 - 25)	6	N/A		UT1, VT2, WT3	8 - 2/0 (10 - 70)	1	LCA1-56-E
	⊕	14 - 8 (2.5 - 10)	10	LCA10-14-L		⊕	14 - 4 (2.5 - 25)	8	LCA8-14-L		⊕	8 - 2/0 (10 - 70)	1	LCA1-56-E
4021	RL1, SL2, TL3 UT1, VT2, WT3	14 - 8 (2.5 - 10)	10	N/A	4052	RL1, SL2, TL3 UT1, VT2, WT3	14 - 4 (2.5 - 25)	6	N/A	4124	RL1, SL2, TL3	8 - 2/0 (10 - 70)	1/0	LCA1/0-56-X
	-, +1	14 - 8 (2.5 - 10)	10	N/A		-, +1	14 - 4 (2.5 - 25)	4	N/A		UT1, VT2, WT3	8 - 2/0 (10 - 70)	2/0	LCA2/0-56-X
	⊕	14 - 8 (2.5 - 10)	10	LCA10-14-L		⊕	14 - 4 (2.5 - 25)	8	LCA8-14-L		⊕	8 - 2/0 (10 - 70)	2/0	LCA2/0-56-X

\*1 The metric wire gauge values are provided as reference information from equivalent AWG sizes and not exactly the same sizes as the AWG/kcmil values. Obey local safety regulations for wire sizes and make sure that the ferrule or crimp terminals are correct for your size.  
 \*2 For use with Panduit Corp. heat-shrinkable tubing HSTT series or an equivalent UL-recognized heat shrinkable tubing rated 600 V minimum.  
 \*3 Refer to the Installation & Primary Operation (TOEPC7106171F) for possible Panduit Type P and Type S crimp terminal alternatives.

**Required Short Circuit Protection**

Install one of the types of short circuit protection devices listed here to comply with UL 508C. Semiconductor protective type fuses are recommended, but the tables also show alternative short circuit protection devices.

**Required Short Circuit Protection for FP605 AC Drives (Three-Phase 240 V)**

		2011	2017	2024	2031	2046	2059	2075	2088	2114	
Drive Mounted without Supplemental Enclosure (Using Type 1 Kit)	Eaton/Bussmann Semiconductor Fuse <sup>†</sup> Part Number (Permitted Only in Type 1 Kit)	Not allowed. Does not support internal fuses for these drive models.									
	Class CC, J, or T Fuse <sup>*2</sup> Maximum Amps	17.5	25	40	50	80	100	125	150	200	
Drive Mounted in Supplemental Enclosure	Any Size Protected Enclosure (Ventilated or Non-Ventilated)	Eaton/Bussmann Semiconductor Fuse <sup>†</sup> Part Number	FWH-40B	FWH-45B	FWH-80B	FWH-125B	FWH-125B	FWH-175B	FWH-200B	FWH-225A	FWH-225A
	Class CC, J, or T Fuse <sup>*2,*3</sup> Maximum Amps	17.5	25	40	50	80	100	125	150	200	
	Class CC, J, or T Fuse <sup>*2,*3</sup> Maximum Amps	Enclosure volume not restricted. Refer to the values in the row above for fuses.									
	MCCB <sup>†</sup> Maximum Amps	25	40	60	75	110	125	175	200	250	
	Schneider MCP <sup>†</sup> Part Number HLLxxxxxxx	36030M71	36030M71	36050M72	36050M72	36100M73	36100M73	36150M74	36150M74	36150M74	
Enclosure Volume Minimum (in³)	External Heatsink	3056	3056	3056	3056	5520	5520	5520	5520	5520	
	Internal Heatsink	3056	3056	3056	3056	5520	5520	5520	5520	5520	

\*1 Protection device must be in same enclosure with drive.  
 \*2 Class T fuses are fast-acting (non-time-delay) only. Class CC and J can be either time-delay or non-time-delay.  
 \*3 Protection device and drive permitted in same or separate enclosure.

### Required Short Circuit Protection for FP605 AC Drives (Three-Phase 480 V)

		4005	4008	4011	4014	4021	4027	4034	4040	4052	4065	4077	4096	4124	
Drive Mounted without Supplemental Enclosure (Using Type 1 Kit)	Eaton/Bussmann Semiconductor Fuse <sup>1</sup> Part Number (Permitted Only in Type 1 Kit)	Not allowed. Does not support internal fuses for these drive models.													
	Class CC, J, or T Fuse <sup>2</sup> Maximum Amps	8	12	17.5	20	35	45	60	70	90	110	125	150	200	
Drive Mounted in Supplemental Enclosure	Any Size Protected Enclosure (Ventilated or Non-Ventilated)	Eaton/Bussmann Semiconductor Fuse <sup>1</sup> Part Number	FWH-25A14F	FWH-30A14F	FWH-40B	FWH-45B	FWH-60B	FWH-80B	FWH-100B	FWH-125B	FWH-150B	FWH-200B	FWH-225A	FWH-225A	
		Class CC, J, or T Fuse <sup>2,3</sup> Maximum Amps	8	12	17.5	20	35	45	60	70	90	110	125	150	200
	Restricted Size Protected Enclosure (Ventilated Only)	Class CC, J, or T Fuse <sup>2,3</sup> Maximum Amps	Enclosure volume not restricted. Refer to the values in the row above for fuses.												
		MCCB <sup>3</sup> Maximum Amps	15	15	25	35	50	60	80	100	125	150	175	225	300
	Schneider MCP <sup>4</sup> Part Number HLLxxxxxxx	36030M71	36030M71	36030M71	36030M71	36030M71	36050M72	36050M72	36100M73	36100M73	36100M73	36100M73	36150M74	36250M75 <sup>4</sup>	
	External Heatsink	3056	3056	3056	3056	3056	3056	3056	5520	5520	5520	5520	5520	5520	
	Enclosure Volume Minimum (in <sup>3</sup> )	3056	3056	3056	3056	3056	3056	3056	5520	5520	5520	5520	5520	5520	
	Internal Heatsink	3056	3056	3056	3056	3056	3056	3056	5520	5520	5520	5520	5520	5520	

\*1 Protection device must be in same enclosure with drive.  
 \*2 Class T fuses are fast-acting (non-time-delay) only. Class CC and J can be either time-delay or non-time-delay.  
 \*3 Protection device and drive permitted in same or separate enclosure.  
 \*4 The MCP part number for model 4124 is JLLxxxxxxx.

### 5 Remove the Front Cover and Keypad

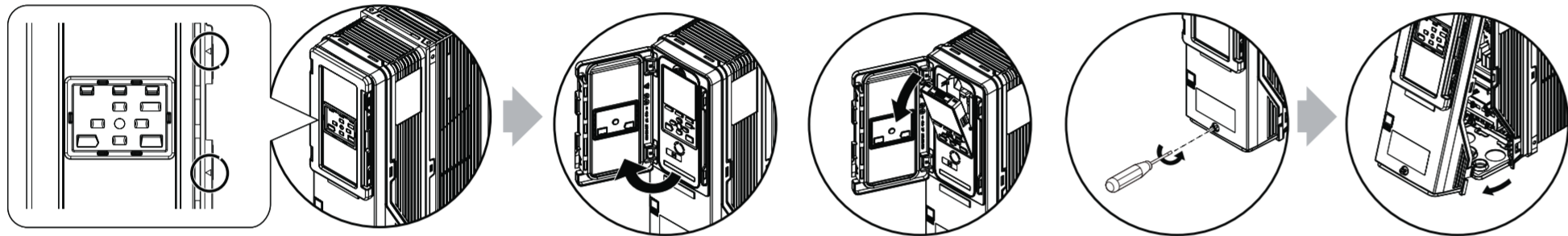

### 6 Install the Motor Wiring and Power Wiring

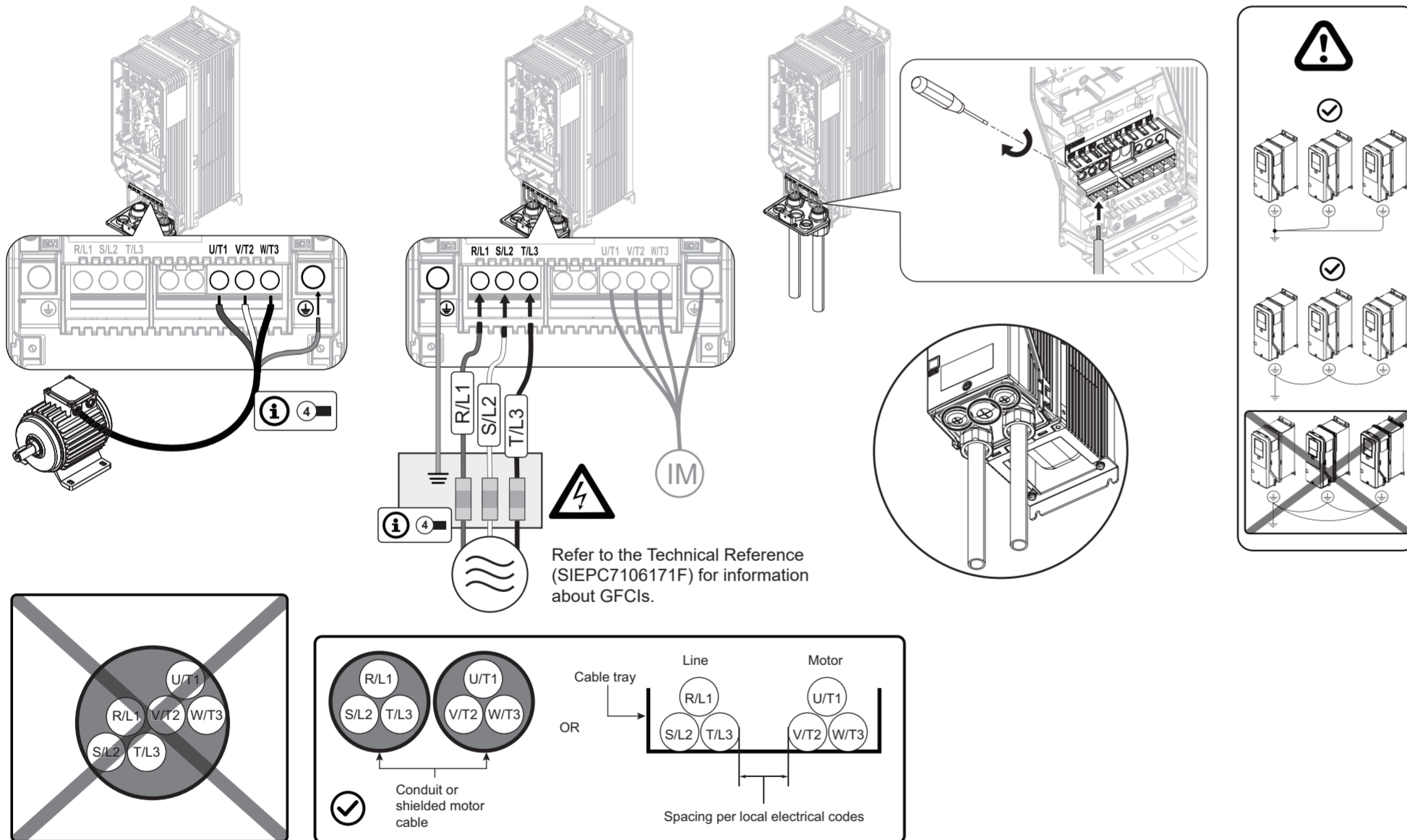

### 7 Install the Front Cover and Keypad

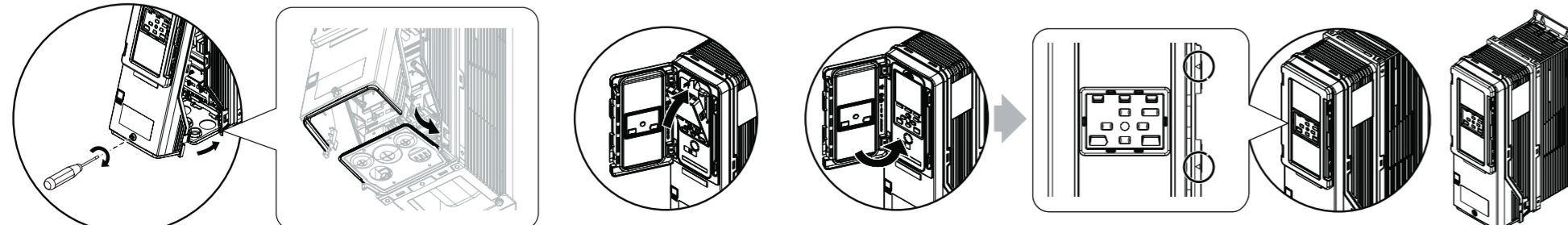

### 8 Energize the Drive and Confirm It Is Ready

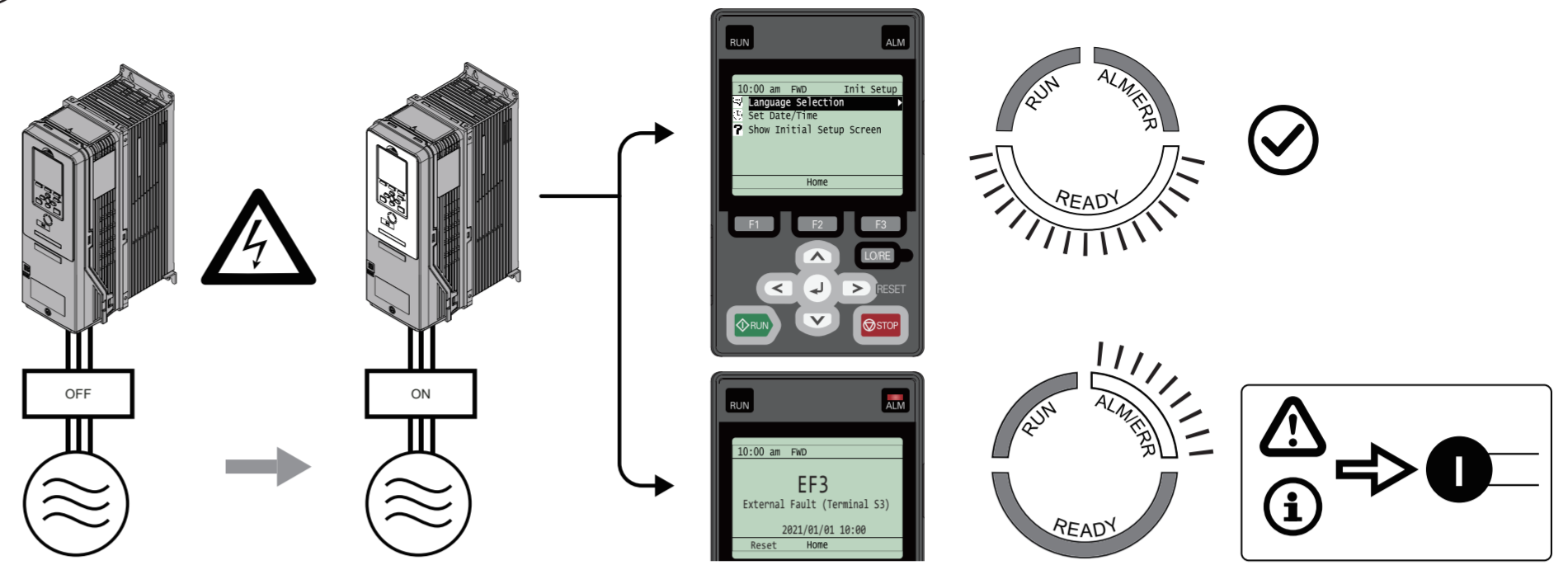

### 9 Set the Motor Rated Current (FLA) from the Motor Nameplate in E2-01

3 PHASE INVERTER DUTY AC INDUCTION MOTOR NAMEPLATE EXAMPLE									
MODEL	XX	123AAAA123XX-X0		X	FRAME 123AX				
POLES	X	ENC XXX	CODE X	DES A	TYPE ABC	INS X0			
VOLTS	XXX	FL RPM	XXXX	FL AMPS	XX/XX				
SF 1.0	DUTY CONT	MAX AMB °C	XX	TEMP SENSORS	T-STATS				
SERIAL		N.L. AMPS	XX.XX.X						
MAX RPM	4200	S.E. BRG. 309	O.S.E. BRG.	XXX	ROTOR WK <sup>2</sup>	X.X			
HZ	kW	RPM	TORQUE (LB FT)	VOLTS (HIGH CONN)	AMPS (HIGH CONN)				
1	-	0	XX.X	-	XX.X				
60	XX	XXXX	XX.X	XXX	XX.X				
120	XX	XXXX	XX.X	XXX	XX.X				
OHMS PH.	R1: .XXX	R2: .XXX	x1: X.XX	x2: .XXX	xM: XX.X				
	PIN	XXXXXX							

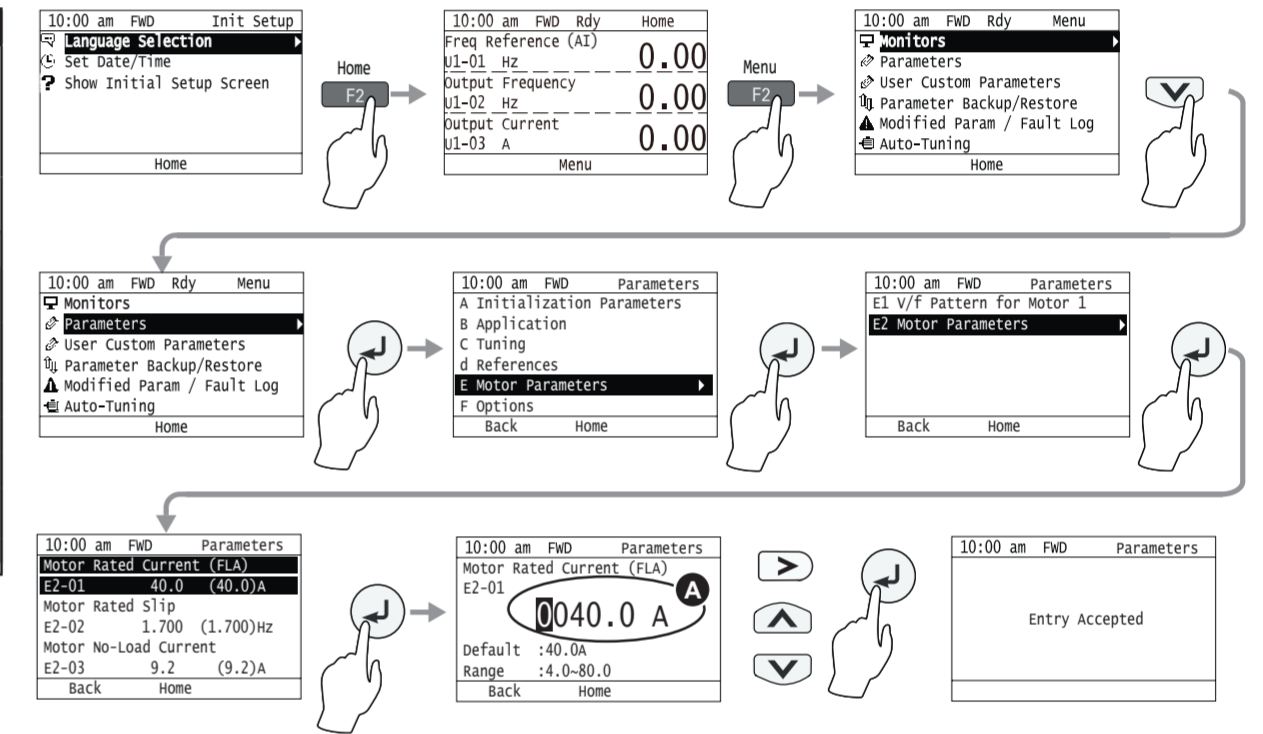

### 10 Set the Drive for LOCAL Control and Check the Motor Rotation Direction

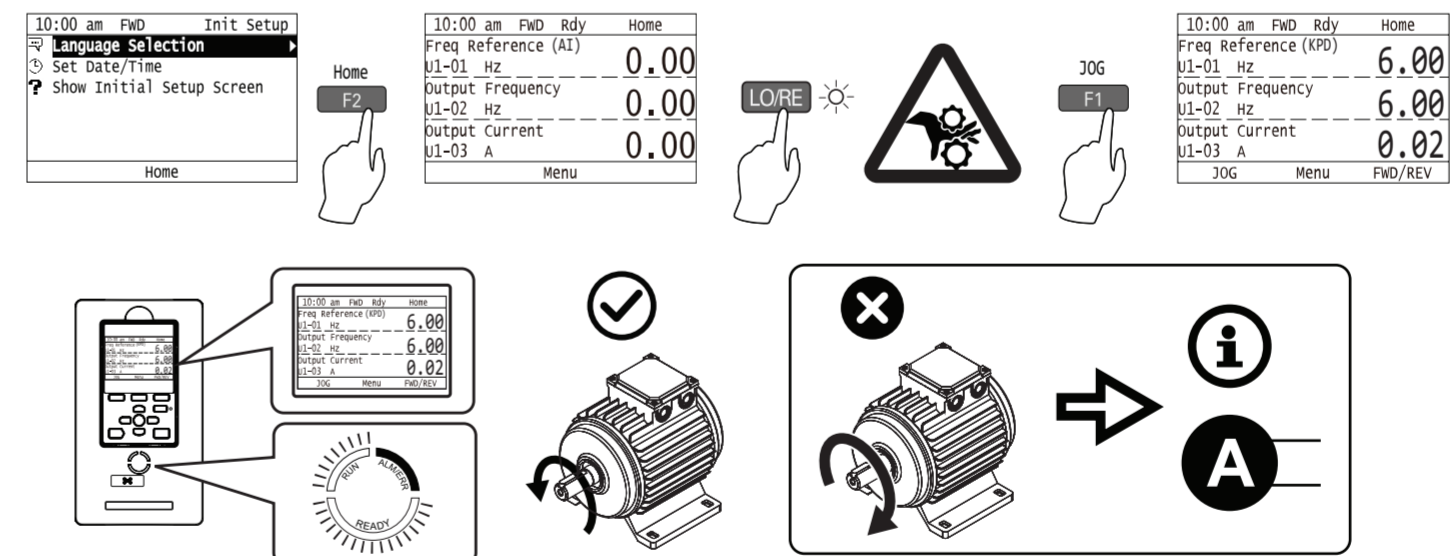



### Additional Information for Installation and Primary Operation

#### A If the Motor Does Not Rotate in the Correct Direction

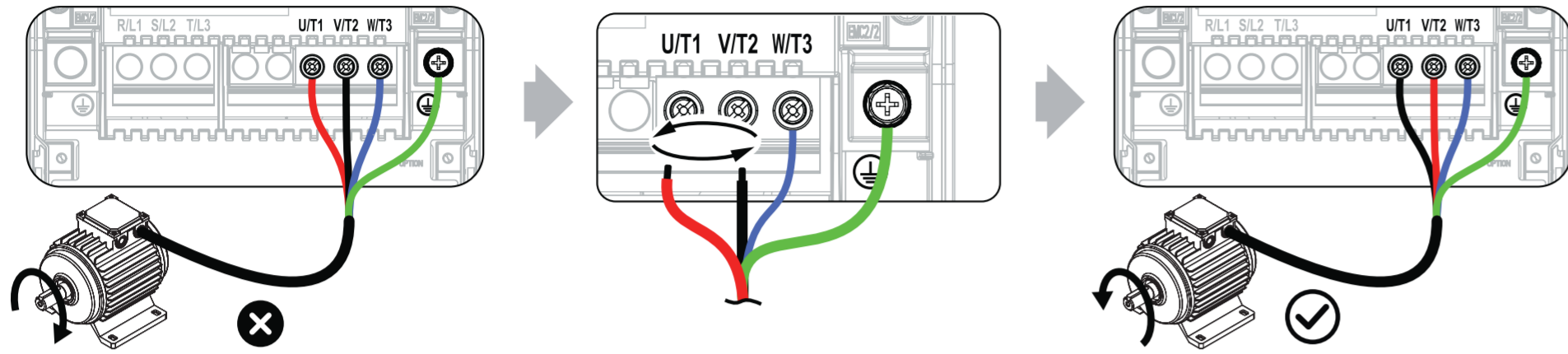

#### B Control Circuit Configuration

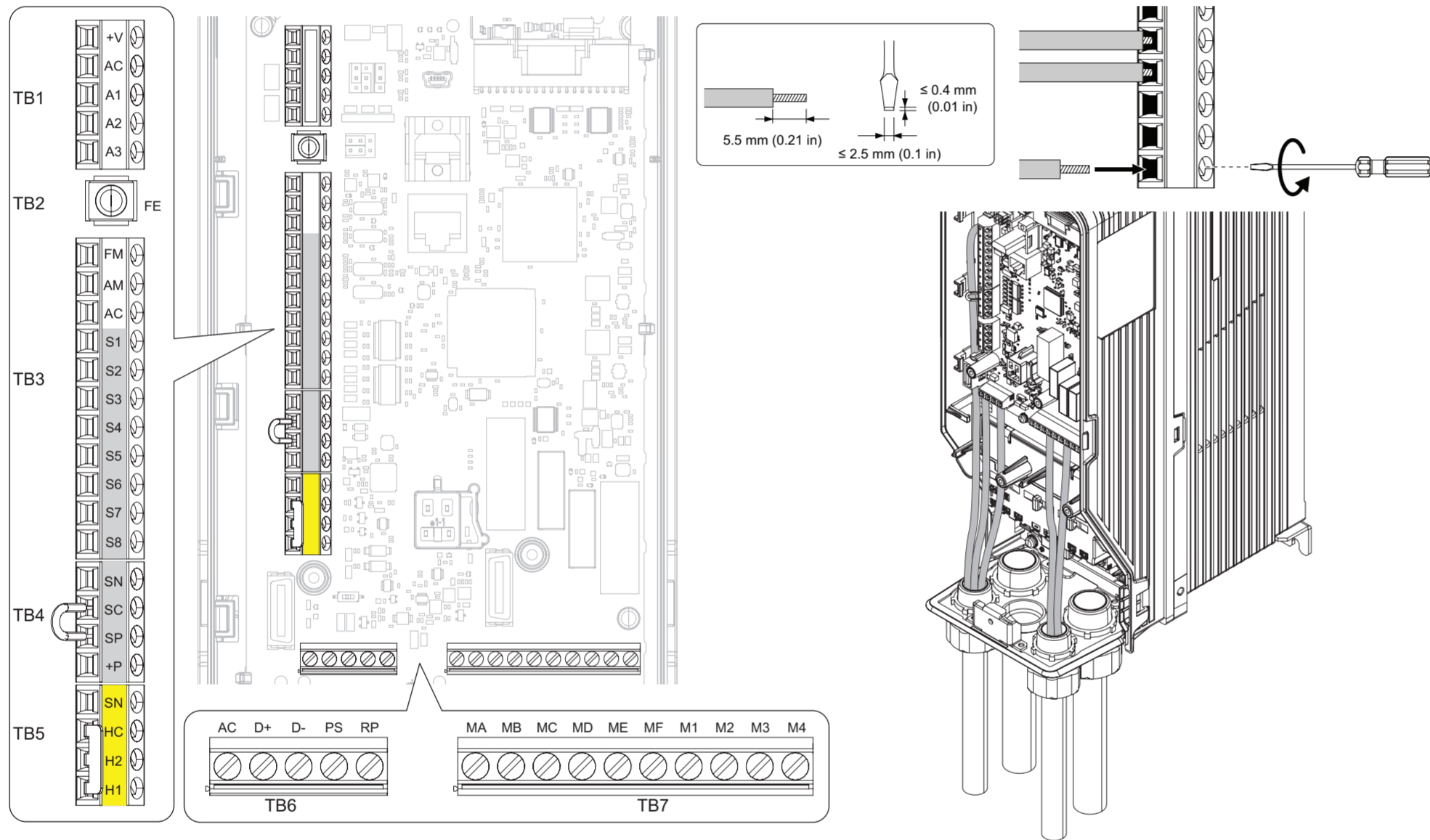

#### C Switches and Jumpers on the Control Board

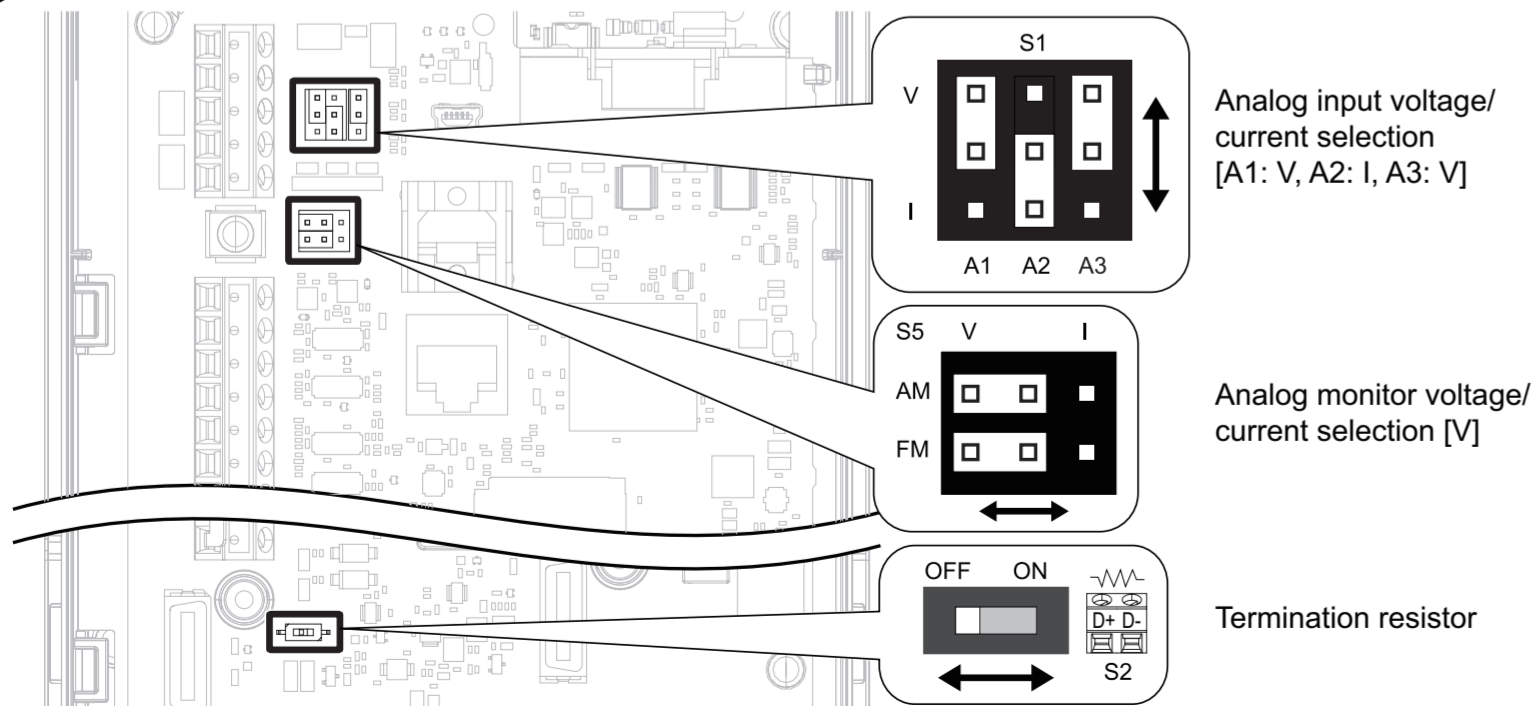

#### D Connection Diagram and Terminal Functions

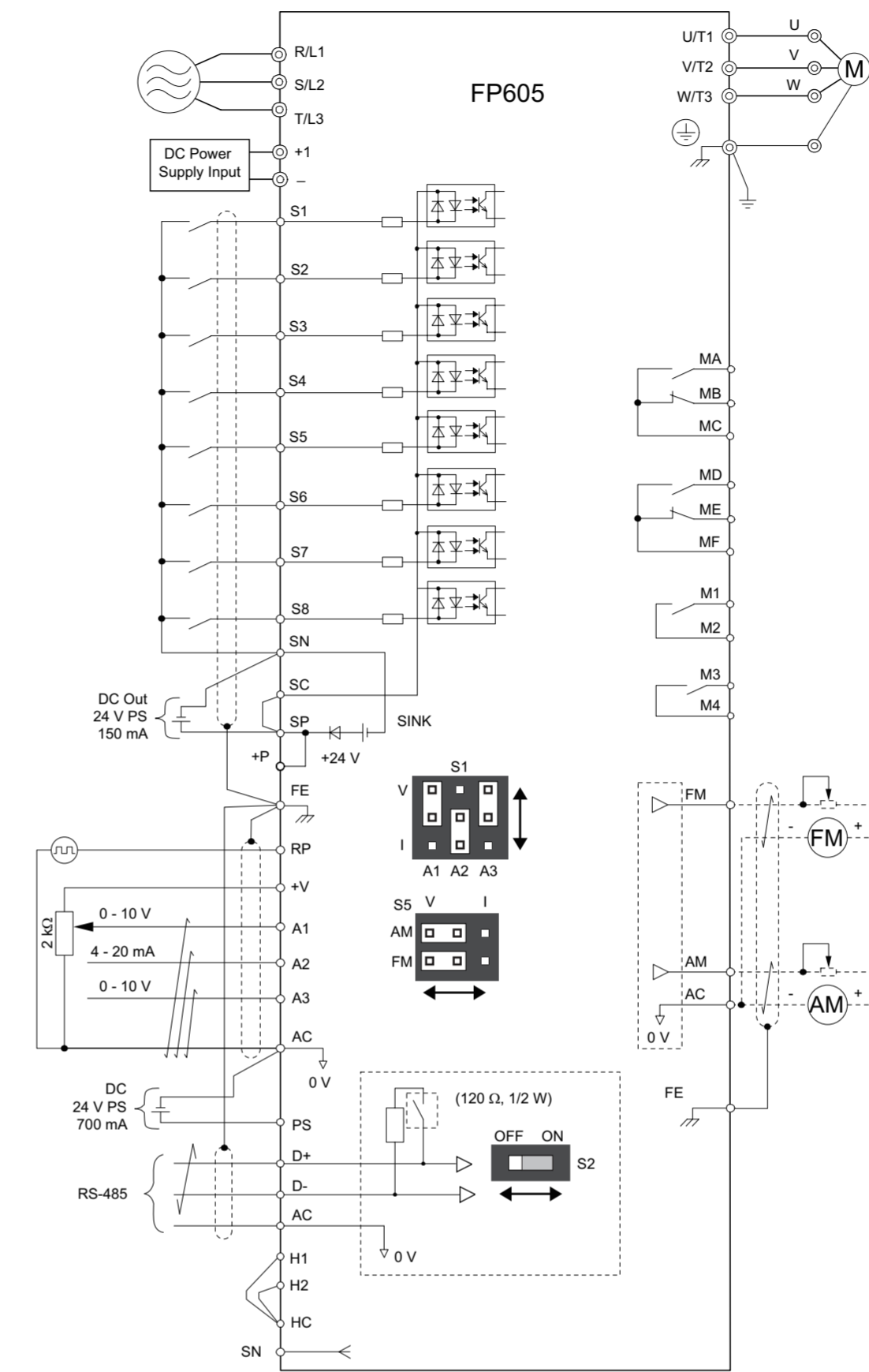

Terminal	Type	Signal Level	Default
S1	MFDI 1	Photocoupler 24 V, 6 mA Internal impedance: 4.7 kΩ	Forward RUN (2-Wire)
S2	MFDI 2		Reverse RUN (2-Wire)
S3	MFDI 3		External Fault (NO-Always-Coast)
S4	MFDI 4		Fault Reset
S5	MFDI 5		Multi-Step Speed Reference 1
S6	MFDI 6		Multi-Step Speed Reference 2
S7	MFDI 7		Jog Reference Selection
S8	MFDI 8		Baseblock Command (N.O.)
SN	MFDI common		-
SC	MFDI power 0 V	24 V, 150 mA maximum	-
SP	MFDI power +24 VDC		-
H1	Safe disable input 1	Photocoupler 24 V, 6 mA Internal impedance: 4.7 kΩ	-
H2	Safe disable input 2		-
HC	Safe disable common		-
RP	Multi-function pulse train input	<ul style="list-style-type: none"> <li>Response frequency: 0 Hz ~ 32 Hz</li> <li>H level duty: 30% ~ 70%</li> <li>H level voltage: 3.5 V ~ 13.2 V</li> <li>L level voltage: 0.0 V ~ 0.8 V</li> <li>Input impedance: 3 kΩ</li> </ul>	-
+V	Frequency setting power supply	10.5 V (20 mA maximum)	-
A1	MFAI 1	0 V ~ 10 V/100% (input impedance 20 kΩ)	Master frequency reference
A2	MFAI 2	4 mA ~ 20 mA/100% (input impedance 250 Ω)	Combined w/A1
A3	MFAI 3	0 mA ~ 20 mA/100% (input impedance 250 Ω)	Auxiliary frequency reference 1
AC	Common	0 V	-
FE	Connect shielded cable	-	-
MA	Fault relay out	30 VDC, 10 mA ~ 2 A 250 VAC, 10 mA ~ 2 A Minimum load: 5 V, 10 mA	Fault
MB	Common		Fault
MC	Common		-
MD	MFDO	30 VDC, 10 mA ~ 2 A 250 VAC, 10 mA ~ 2 A Minimum load: 5 V, 10 mA	Speed agree 1
ME	Common		-
MF	Common		-
M1	MFAO 1	0 V ~ +10 V/0% ~ 100%	Output frequency
M2	MFAO 2	4 mA ~ 20 mA	Output current
M3	Common		-
M4	Common		-
FM	Common		-
AM	Common		-
AC	Common	0 V	-
+P	External power supply	24 V (150 mA maximum)	-
PS	External 24 V PS input	21.6 VDC ~ 26.4 VDC, 700 mA	-
AC	External 24 V PS ground	0V	-
D+	Communication +	MEMOBUS/Modbus	-
D-	Communication -	115.2 kbps maximum	-
AC	Common	0 V	-

#### E Set Frequency Reference Source

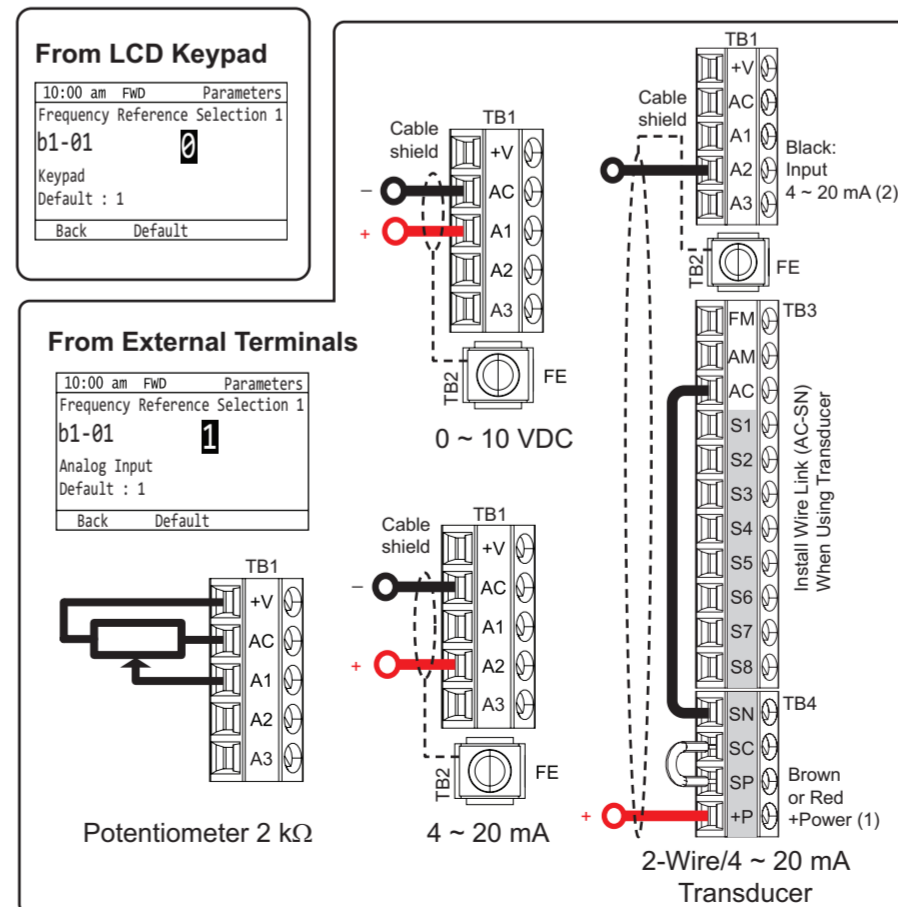

#### F Set Start/Stop Control Method from External Terminals

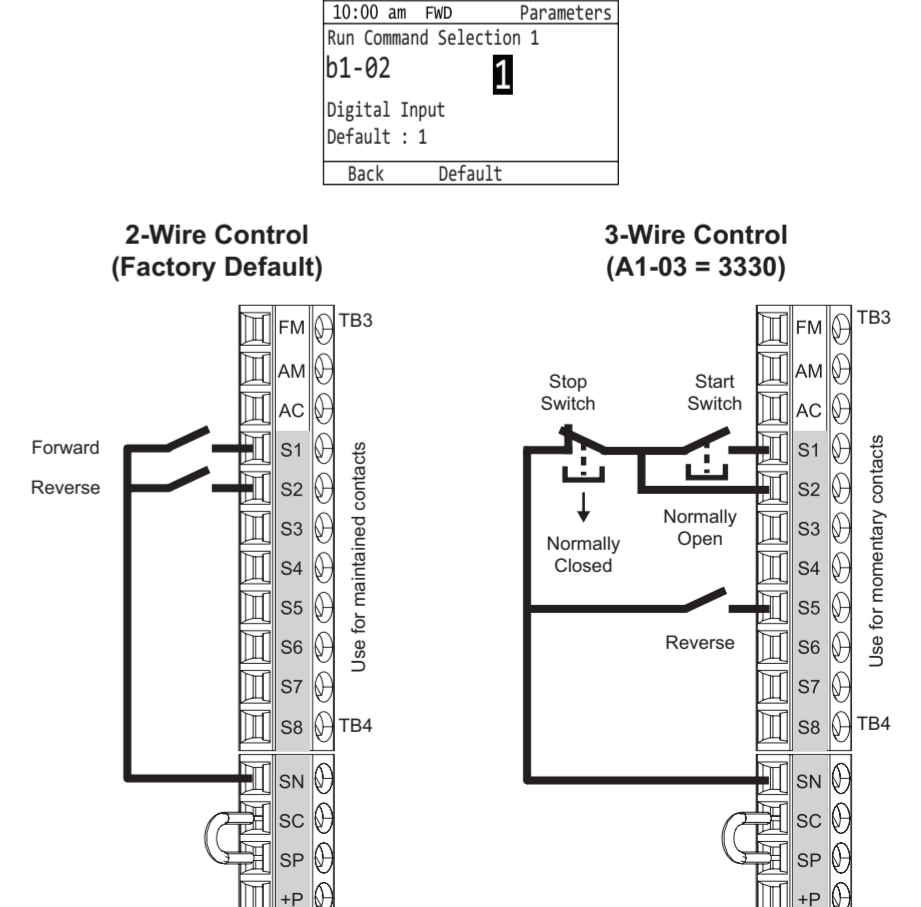

### G If You Push the RUN Button but the Motor Does Not Spin

10:00 am FWD Rdy Home  
 Freq Reference (KPD) 0.00  
 U1-01 Hz  
 Output Frequency 0.00  
 U1-02 Hz  
 Output Current 0.00  
 U1-03 A  
 JOG Menu FWD/REV

10:00 am FWD Rdy Home  
 Freq Reference (AI) 0.00  
 U1-01 Hz  
 Output Frequency 0.00  
 U1-02 Hz  
 Output Current 0.00  
 U1-03 A  
 Menu

10:00 am FWD Parameters  
 Reference 1  
 d1-01 000.00 Hz  
 Default : 0.00 Hz  
 Range : 0.00-60.00  
 Back Default Min/Max

10:00 am FWD Parameters  
 Reference 1  
 d1-01 10.00 Hz  
 Default : 0.00 Hz  
 Range : 0.00-60.00  
 Back Default Min/Max

10:00 am FWD Rdy Home  
 Freq Reference (KPD) 10.00  
 U1-01 Hz  
 Output Frequency 0.00  
 U1-02 Hz  
 Output Current 0.00  
 U1-03 A  
 JOG Menu FWD/REV

10 Hz

### H Parameter Groups

A: Initialization	d: Reference Settings	H: Terminal Functions	n: Special Adjustment	Y: Application Features
A1 Initialization	d1 Frequency Reference	H1 Digital Inputs	n1 Hunting Prevention	Y1 Application Basics
A2 User Parameters	d2 Reference Limits	H2 Digital Outputs	n3 High Slip/Overexcite Braking	Y2 PID Sleep and Protection
<b>b: Application</b>				
b1 Operation Mode Selection	d3 Jump Frequency	H3 Analog Inputs	n7 EZ Drive	Y3 Contactor Multiplex
b2 DC Injection Braking and Short Circuit Braking	d4 Freq. Ref. Up/Down & Hold	H4 Analog Outputs	n8 PM Motor Control Tuning	Y4 Application Advanced
b3 Speed Search	d6 Field Weakening	H5 Modbus Communication	<b>o: Keypad-Related Settings</b>	
b4 Timer Function	d7 Offset Frequency	H6 Pulse Train Input	o1 Keypad Display	Y8 De-Scale/De-Rag
b5 PID Control	<b>E: Motor</b>		o2 Keypad Operation	YA Preset Setpoint
b6 Dwell Function	E1 V/f Pattern for Motor 1	H7 Virtual Inputs/Outputs	o3 Copy Keypad Function	YC Feedback Features
b8 Energy Saving	E2 Motor Parameters	<b>L: Protection Functions</b>		YF PI Auxiliary Control
<b>C: Tuning</b>				
C1 Accel & Decel Time	E3 V/f Pattern for Motor 2	L1 Motor Protection	<b>S: Special Applications</b>	
C2 S-Curve Characteristics	E4 Motor 2 Parameters	L2 Power Loss Ride Through	S1 Dynamic Noise Control	
C3 Slip Compensation	E5 PM Motor Settings	L3 Stall Prevention	S3 PI2 Control	
C4 Torque Compensation	E9 Motor Setting	L4 Speed Detection	S6 Protection	
C5 Auto Speed Regulator (ASR)	<b>F: Options</b>		<b>T: Auto-Tuning</b>	
C6 Carrier Frequency	F2 Analog Input Option	L6 Torque Detection	T1 InductionMotor Auto-Tuning	
	F3 Digital Input Option	L7 Torque Limit	T2 PM Motor Auto-Tuning	
	F4 Analog Output Option	L8 Drive Protection	T4 EZ Tuning	
	F5 Digital Output Option	L9 Drive Protection 2		
	F6 Communication Options			
	F7 Ethernet Options			

#### Frequently Used Parameters

Parameter Number   Name	Default   Description	Parameter Number   Name	Default   Description	Parameter Number   Name	Default   Description
A1-06   Application Preset	0   No preset	b5-03   Integral Time (I)	1.0 s	d2-02   Frequency Reference Lower Limit	0.0%
b1-01   Frequency Reference Selection 1	1   Analog Input	b5-05   Derivative Time (D)	0.00 s	E1-01   Input AC Supply Voltage	-
b1-02   Run Command Selection 1	1   Digital Input	C1-01   Acceleration Time 1	10.0 s	E2-01   Motor Rated Current (FLA)	-
b1-03   Stopping Method Selection	1   Coast to Stop	C1-02   Deceleration Time 1	10.0 s	H3-09   Terminal A2 Signal Level Select	2   4 to 20 mA
b5-01   PID Mode Setting	0   Disabled	d2-01   Frequency Reference Upper Limit	100.0%	H3-10   Terminal A2 Function Selection	0   Frequency Reference
b5-02   Proportional Gain (P)	1.00				

### I Troubleshooting Resources for Drive Faults and Alarms

Resource	Choose This When:	URL	QR Code
Installation & Primary Operation	You have access to the paper copy of the manual that was packaged with the drive. This manual lists all drive faults and alarms, and offers a selection of causes and solutions.	<a href="https://www.yaskawa.com/toepec7106171f">https://www.yaskawa.com/toepec7106171f</a>	 PDF download
DriveWizard Mobile App	You want to use your smartphone or tablet and use the embedded help to look up the full complement of causes and solutions to all drive faults and alarms.	<a href="https://www.yaskawa.com/dwm">https://www.yaskawa.com/dwm</a>	 App download
Maintenance & Troubleshooting Manual	You want to download a PDF of the manual to your smartphone or tablet. This manual lists the full complement of causes and solutions to all drive faults and alarms and also includes detailed information about drive maintenance, wiring, and programming.	<a href="https://www.yaskawa.com/toeypaifp6001">https://www.yaskawa.com/toeypaifp6001</a>	 PDF download

### J Additional Resources

Download on the App Store

GET IT ON Google Play

Mobile App

Product Manuals

•PDFs  
•Online HTML5-Searchable  
•Manuals App

<https://www.yaskawa.com/dwm>

<https://www.yaskawa.com/tp605manuals>

DriveWizard® Mobile Commissioning Smartphone App

DriveWizard is a registered trademark of Yaskawa America, Inc. and is registered in the U.S. Patent and Trademark Office.

### K Customer Feedback

Comments or questions about this document? Fill out our online form:

Please consider following us on social media:

YouTube [www.youtube.com/yaskawayea](http://www.youtube.com/yaskawayea)

in [www.linkedin.com/company/18822](http://www.linkedin.com/company/18822)

www.twitter.com/yaskawa

OR

Email us: [technical\\_documentation@yaskawa.com](mailto:technical_documentation@yaskawa.com)  
 Call us: 1-800-YASKAWA (927-5292)  
[www.yaskawa.com/DRV-F-0006](http://www.yaskawa.com/DRV-F-0006)

**Headquarters Address:**  
 YASKAWA AMERICA, INC.  
 2121 Norman Drive South  
 Waukegan, IL 60085  
 USA  
 © 2021 YASKAWA Electric Corporation  
 MANUAL NO. TOEP C710617 1DB <1>-0  
 Published in Japan August 2022